

STON

Aufsteckgetriebe
Shaft mounted gearboxes

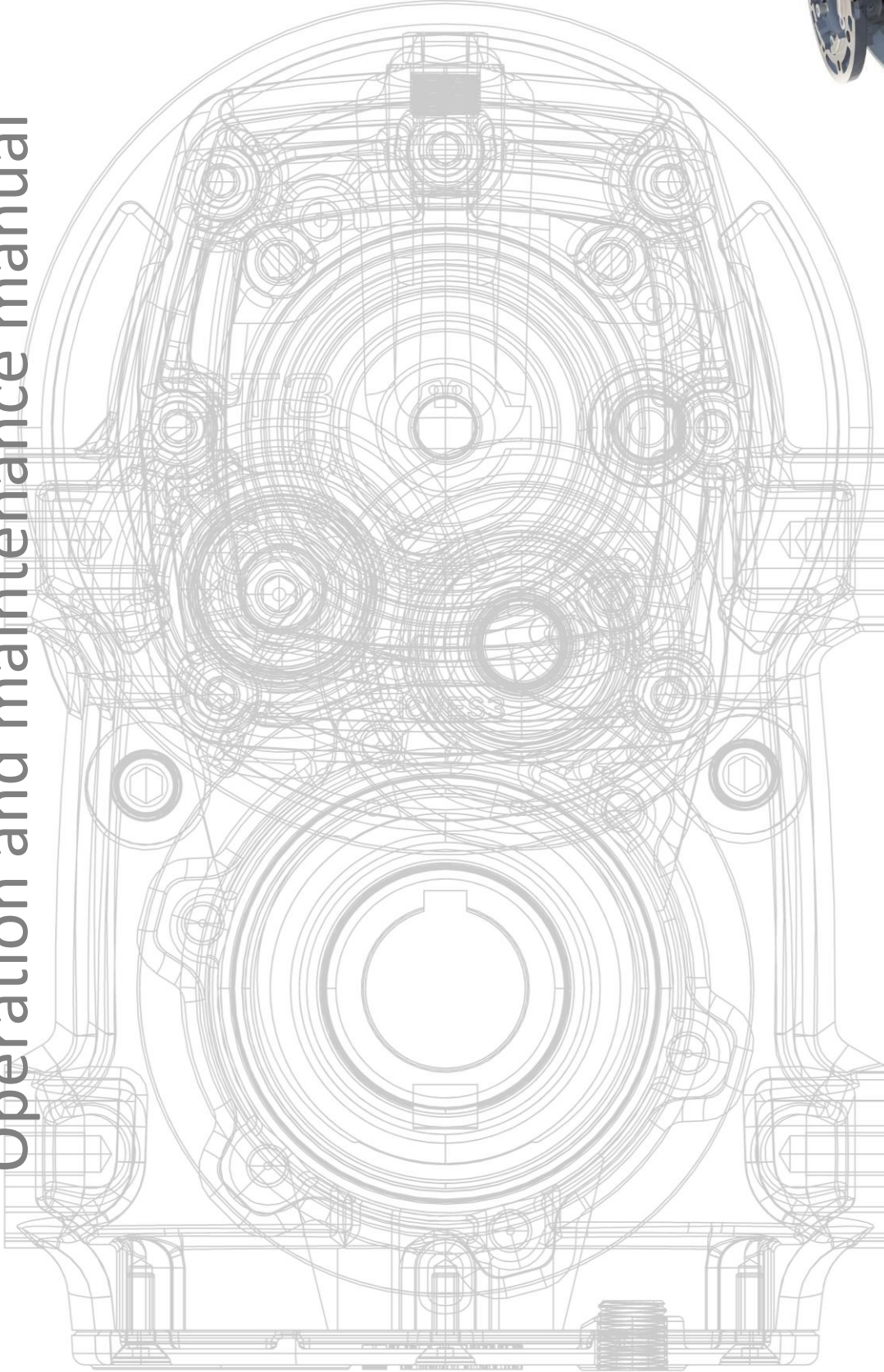

Technisches Handbuch
Operation and maintenance manual



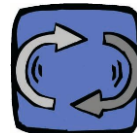

AUFSTELLUNG BESTANDTEILE (2 STUFIG) – COMPONENTS LIST (25-60 2 STAGES)

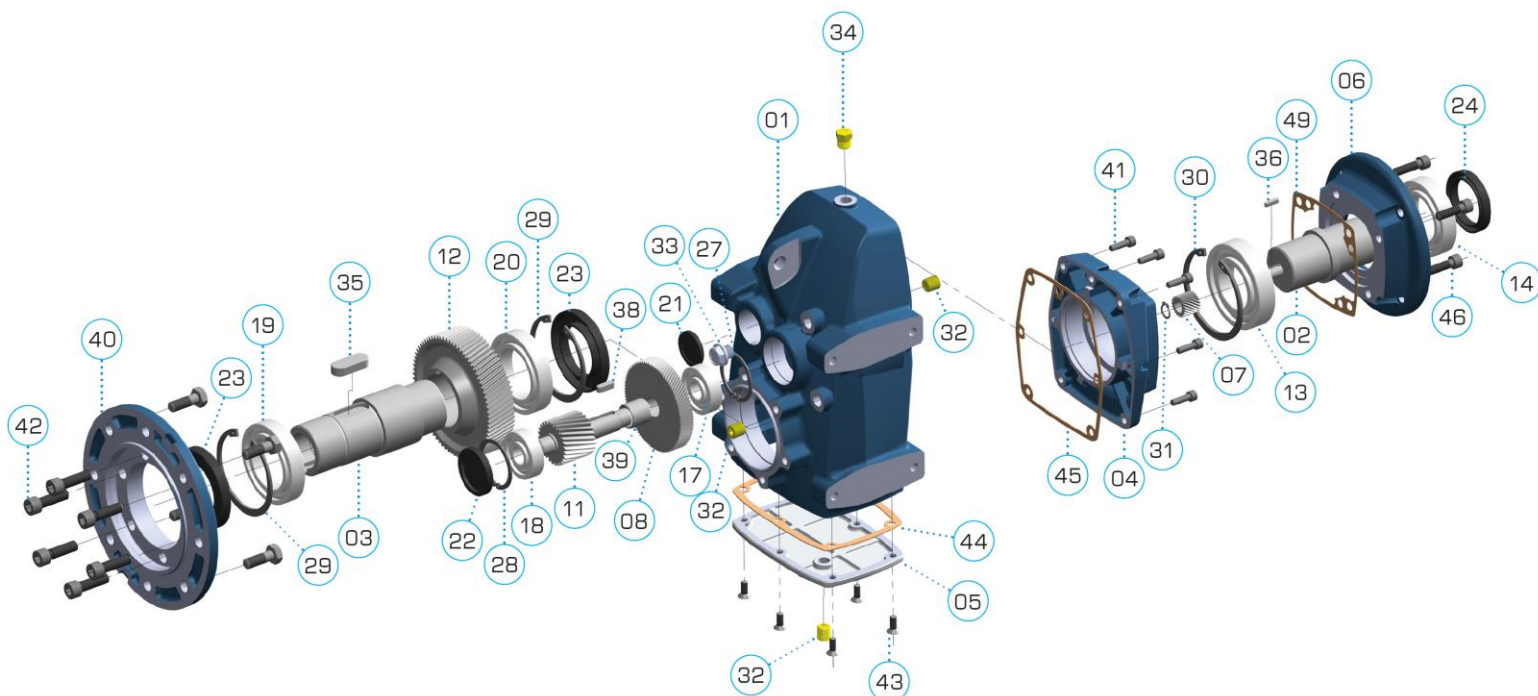

STON 3		STON 4		STON 5		STON 7		STON 8		STON 9	
art. code	description	q.ty	description	q.ty	description	q.ty	description	q.ty	description	q.ty	description
1	HOUST... housing	1	housing	1	housing	1	housing	1	housing	1	housing
2	ISHDM...ID... input shaft	1	input shaft	1	input shaft	1	input shaft	1	input shaft	1	input shaft
3	OSHST... output shaft	1	output shaft	1	output shaft	1	output shaft	1	output shaft	1	output shaft
4	ICVES... input cover	1	input cover	1	input cover	1	input cover	1	input cover	1	input cover
5	TCVES... adapter cover	1	adapter cover	1	adapter cover	1	adapter cover	1	adapter cover	1	adapter cover
6	IFL... Input flange 63B5	1	Input flange 71B5	Input flange 71B5	Input flange 80/90B5	Input flange 80/90B5	Input flange 100/112B5	Input flange 100/112B5	Input flange 132B5	Input flange 160/180B5	Input flange 200B5
	Input flange 80/90B5		Input flange 80/90B5	Input flange 100/112B5	Input flange 132B5	Input flange 160/180B5	Input flange 200B5				
	Input flange 100/112B5		Input flange 100/112B5	Input flange 132B5	Input flange 160/180B5	Input flange 200B5	Input flange 200B5				
	Input flange 132B5		Input flange 160/180B5	Input flange 200B5	Input flange 200B5						
7	P1... pinion first stage	1	pinion first stage	1	pinion first stage	1	pinion first stage	1	pinion first stage	1	pinion first stage
8	G1... gear first stage	1	gear first stage	1	gear first stage	1	gear first stage	1	gear first stage	1	gear first stage
11	P3...ST... pinion third stage	1	pinion third stage	1	pinion third stage	1	pinion third stage	1	pinion third stage	1	pinion third stage
12	G3...ST... gear third stage	1	gear third stage	1	gear third stage	1	gear third stage	1	gear third stage	1	gear third stage
13	BEA... bearing 6008 ZZ	1	bearing 6009 ZZ	1	bearing 6009 ZZ	1	bearing 6211 ZZ	1	bearing 6213ZZ-C3 (IFL90-112) bearing 6009ZZ-C3 (IFL132-180)	1	bearing 6216 ZZ
14	BEA... bearing 6008 ZZ	1	bearing 6009 ZZ	1	bearing 6009 ZZ	1	bearing 6210 ZZ	1	bearing 6213ZZ-C3 (IFL90-112) bearing 6009ZZ-C3 (IFL132-180)	1	bearing 6215 ZZ
17	BEA... bearing 7202 ZZ	1	bearing 7303 ZZ	1	bearing 7304 ZZ	1	bearing 30304	1	bearing 30306	1	bearing 30307
18	BEA... bearing 7302 ZZ	1	bearing 7303 ZZ	1	bearing 7304 ZZ	1	bearing 32206	1	bearing 30308	1	bearing 32208
19	BEA... bearing 6009 ZZ	1	bearing 6010 ZZ	1	bearing 6211 ZZ	1	bearing 6014 ZZ	1	bearing 6017 ZZ	1	bearing 6219 ZZ
20	BEA... bearing 6009 ZZ	1	bearing 6010 ZZ	1	bearing 6211 ZZ	1	bearing 6014 ZZ	1	bearing 6017 ZZ	1	bearing 6219 ZZ
21	COVD... plug seal D35X5	1	plug seal D35X5	1	plug seal 80X40 40x7	1	plug seal D52X7	1	plug seal D72X12	1	plug seal D72X12
22	COVD... plug seal D42X6	1	plug seal D47X7	1	plug seal D52x7	1	plug seal D62X7	1	plug seal D90X10	1	plug seal D80X10
23	OS... oil seal 45X75X8	2	oil seal 50X80X10	2	oil seal 55X100X10	2	oil seal 70X110X12	2	oil seal 85X130X12	2	oil seal 95X170X12
24	OS... oil seal 40X55X8	1	oil seal 45X60X9	1	oil seal 45X60X9	1	oil seal 55X80X10	1	oil seal 45X65X10 (IFL80-112) oil seal 65X90X12 (IFL132-180)	1	oil seal 80X105X13
32	FPL... filler plug 1/4"	3	filler plug 1/4"	3	filler plug 1/4"	3	filler plug 1/4"	3	filler plug 1/4"	3	filler plug 1/4"
33	LPL... level plug 1/4"	1	level plug 1/4"	1	level plug 1/4"	1	level plug 1/4"	1	level plug 1/4"	1	level plug 1/4"
34	BPL... breather plug 1/4"	1	breather plug 1/4"	1	breather plug 1/4"	1	breather plug 1/4"	1	breather plug 1/4"	1	breather plug 1/4"
39	SPR39ST... spacer ST3-2	1	spacer ST4-2	1	spacer ST5-2	1	spacer ST7-2	1	spacer ST8-2	1	spacer ST9-2
40	OFL...ES... output flange	1	output flange	1	output flange	1	output flange	1	output flange	1	output flange
44	GK44ES... adapter cover gasket	1	adapter cover gasket	1	adapter cover gasket	1	adapter cover gasket	1	adapter cover gasket	1	adapter cover gasket
45	GK45ES... input cover gasket	1	input cover gasket	1	input cover gasket	1	input cover gasket	1	input cover gasket	1	input cover gasket
49	GK49RB... input flange gasket	1	input flange gasket	1	input flange gasket	1	input flange gasket	1	input flange gasket	1	input flange gasket

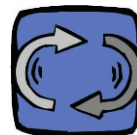

AUFSTELLUNG BESTANDTEILE (3 STUFIG) – COMPONENTS LIST (3 STAGES)

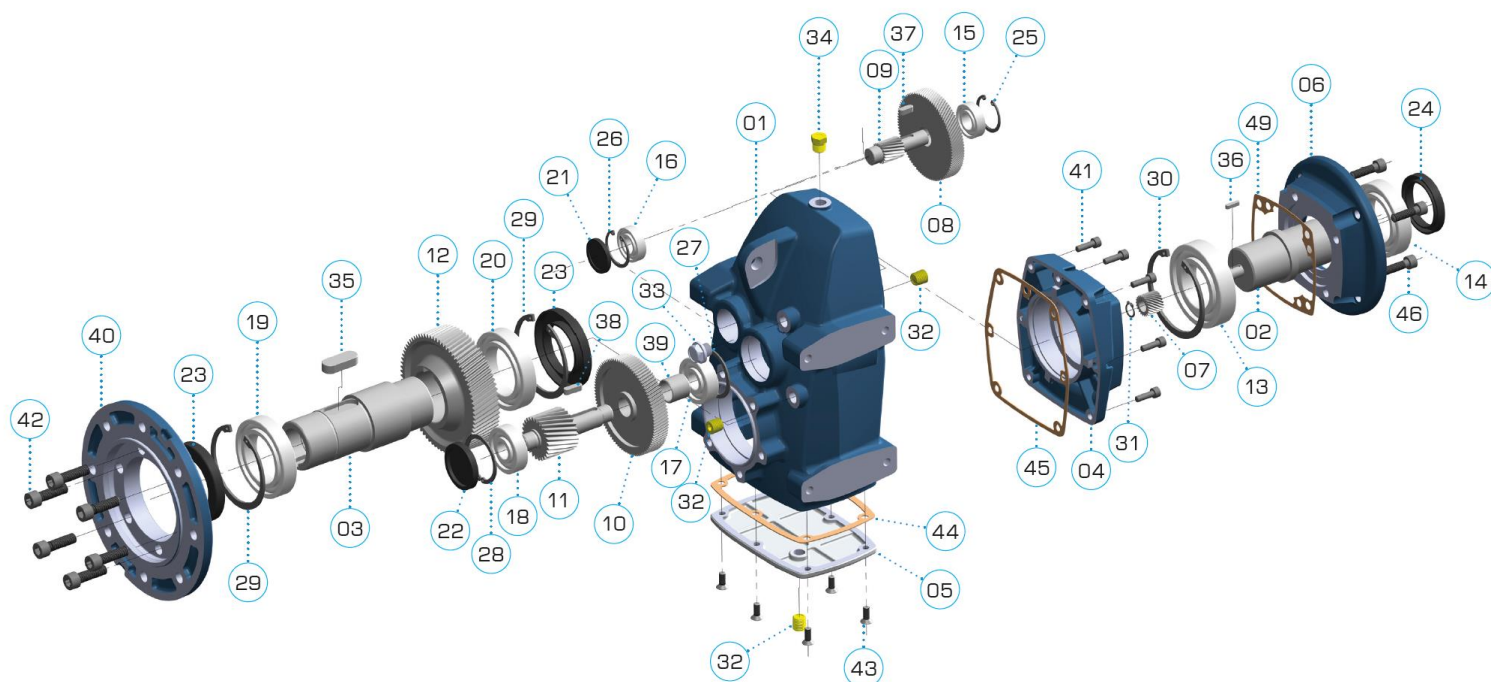

STON 3		STON 4		STON 5		STON7		STON8		STON9	
art. code	description	q.ty	description	q.ty	description	q.ty	description	q.ty	description	q.ty	description
1	HOUST...	1	housing	1	housing	1	housing	1	housing	1	housing
2	ISHDM...ID...	1	input shaft	1	input shaft	1	input shaft	1	input shaft	1	input shaft
3	OSHST...	1	output shaft	1	output shaft	1	output shaft	1	output shaft	1	output shaft
4	ICVES...	1	input cover	1	input cover	1	input cover	1	input cover	1	input cover
5	TCVES...	1	adapter cover	1	adapter cover	1	adapter cover	1	adapter cover	1	adapter cover
6	Input flange 63B5	1	Input flange 71B5	1	Input flange 71B5	1	Input flange 80/90B5	1	Input flange 80/90B5	1	Input flange 100/112B5
	Input flange 71B5		Input flange 80/90B5		Input flange 100/112B5		Input flange 132B5				
	Input flange 80/90B5		Input flange 100/112B5		Input flange 160/180B5		Input flange 200B5				
	Input flange 100/112B5		Input flange 132B5		Input flange 160/180B5		Input flange 200B5				
7	P1...	1	pinion first stage	1	pinion first stage	1	pinion first stage	1	pinion first stage	1	pinion first stage
8	G1...	1	gear first stage	1	gear first stage	1	gear first stage	1	gear first stage	1	gear first stage
9	P2...	1	pinion second stage	1	pinion second stage	1	pinion second stage	1	pinion second stage	1	pinion second stage
10	G2...	1	gear second stage	1	gear second stage	1	gear second stage	1	gear second stage	1	gear second stage
11	P3...ST...	1	pinion third stage	1	pinion third stage	1	pinion third stage	1	pinion third stage	1	pinion third stage
12	G3...ST...	1	gear third stage	1	gear third stage	1	gear third stage	1	gear third stage	1	gear third stage
13	BEA...	1	bearing 6008 ZZ	1	bearing 6009 ZZ	1	bearing 6211 ZZ	1	bearing 6213ZZ-C3 (IFL90-112) bearing 6009ZZ-C3 (IFL132-180)	1	bearing 6216 ZZ
14	BEA...	1	bearing 6008 ZZ	1	bearing 6009 ZZ	1	bearing 6210 ZZ	1	bearing 6213ZZ-C3 (IFL90-112) bearing 6009ZZ-C3 (IFL132-180)	1	bearing 6215 ZZ
15	BEA...	1	bearing 6002 ZZ	1	bearing 6003 ZZ	1	bearing 6203 ZZ	1	bearing 6206 ZZ	1	bearing 6207 ZZ
16	BEA...	1	bearing 6202 ZZ	1	bearing 6003 ZZ	1	bearing 6203 ZZ	1	bearing 6304 ZZ	1	bearing 6207 ZZ
17	BEA...	1	bearing 6202 ZZ	1	bearing 6303 ZZ	1	bearing 6304 ZZ	1	bearing 30306	1	bearing 30307
18	BEA...	1	bearing 6302 ZZ	1	bearing 6303 ZZ	1	bearing 6304 ZZ	1	bearing 32206	1	bearing 32208
19	BEA...	1	bearing 6009 ZZ	1	bearing 6010 ZZ	1	bearing 6211 ZZ	1	bearing 6014 ZZ	1	bearing 6219 ZZ
20	BEA...	1	bearing 6009 ZZ	1	bearing 6010 ZZ	1	bearing 6211 ZZ	1	bearing 6017 ZZ	1	bearing 6219 ZZ
21	COVD...	1	plug seal D35X5	1	plug seal D35X5	1	plug seal D52X7	1	plug seal D72X12	1	plug seal D72X12
22	COVD...	1	plug seal D42X6	1	plug seal D47X7	1	plug seal D52X7	1	plug seal D90X10	1	plug seal D80X10
23	OS...	2	oil seal 45X75X8	2	oil seal 50X80X10	2	oil seal 55X100X10	2	oil seal 70X110X12	2	oil seal 85X130X12
24	OS...	1	oil seal 40X55X8	1	oil seal 45X60X9	1	oil seal 55X80X10	1	oil seal 45X65X10 (IFL80-112) oil seal 65X90X12 (IFL132-180)	1	oil seal 80X105X13
32	FPL...	3	filler plug 1/4"	3	filler plug 1/4"	3	filler plug 1/4"	3	filler plug 1/4"	3	filler plug 1/4"
33	LPL...	1	level plug 1/4"	1	level plug 1/4"	1	level plug 1/4"	1	level plug 1/4"	1	level plug 1/4"
34	BPL...	1	breather plug 1/4"	1	breather plug 1/4"	1	breather plug 1/4"	1	breather plug 1/4"	1	breather plug 1/4"
39	SPR39ST...	1	spacer ST3-3	1	spacer ST4-3	1	spacer ST5-3	1	spacer ST7-3	1	spacer ST9-3
40	OFL...ES...	1	output flange	1	output flange	1	output flange	1	output flange	1	output flange
44	GK44ES...	1	adapter cover gasket	1	adapter cover gasket	1	adapter cover gasket	1	adapter cover gasket	1	adapter cover gasket
45	GK45ES...	1	input cover gasket	1	input cover gasket	1	input cover gasket	1	input cover gasket	1	input cover gasket
49	GK49RB...	1	input flange gasket	1	input flange gasket	1	input flange gasket	1	input flange gasket	1	input flange gasket

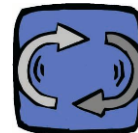

GETRIEBEGRÖSSENWAHL

Der Betriebsfaktor f_{sr} ist ein numerischer Wert, der die Belastung eines Getriebes beschreibt. Der Betriebsfaktor f_s ergibt sich aus dem Nenndrehmoment M_n des Getriebes und der rpm nominellen Geschwindigkeit die der Motor bietet. Der f_s Wert muss \geq als der geforderte f_{sr} Wert sein.

Der f_{sr} berücksichtigt folgende Parameter:

- die täglichen Betriebsstunden h/d
- die Belastungsart und im weiteren Verlauf das Trägheitsmoment der gesteuerten Masse.
- die Anzahl der Starts / Stopps pro Stunde.
- das Vorhandensein von Bremsmotoren
- die Kritizität der Anwendung in Bezug auf Sicherheit (z.B. Lastenheben)

Wenn das Nenndrehmoment eines Getriebemotors M_{n2} höher ist als das angefragte M_{r2} , kann der Betriebsfaktor nach folgender Formel erhöht werden:

$$f_s \text{ gegeben} = \frac{f_s \text{ aus Tabelle} \cdot M_{n2} \text{ aus Tabelle}}{M_{r2}}$$

Der daraus ergebene reale Wert f_s muss $\geq f_{sr}$ sein. Für diese Berechnungen empfehlen wir die Verwendung des Motive – Konfigurators <http://www.motive.it/de/configuratore.php>



Bei gleichem Betriebsfaktor muss beim Anlauf eines Getriebes in beide Drehrichtungen das M_n Nenndrehmoment um 25% verringert werden

GEARBOX SIZE SELECTION

The Service factor f_{sr} is a numeric value describing the gearbox service duty. The service factor f_s is the one offered by the gearbox at the rated input torque M_n and speed rpm of the motor. f_s must be \geq of the requested one f_{sr} .

f_{sr} takes into consideration parameters like:

- the daily working hours h/d
- the load classification, and then the moment of inertia of the driven masses.
- The number of starts per hour s/h
- The presence of brake motors
- The significance of the application in terms of safety, for example lifting of parts

Whenever the rated torque of a gearbox M_{n2} is higher than the requested one M_{r2} , the rated service factor can be increased according to the formula:

$$f_{s \text{ real}} = \frac{f_s \text{ on the table} \cdot M_{n2} \text{ on the table}}{M_{r2}}$$

It is such real value of f_s that must be $\geq f_{sr}$.

For such calculations we recommend the use of Motive configurator <http://www.motive.it/en/configuratore.php>

Keeping the same service factor, if a gearbox is subject to starting in both directions of rotation, you must decrease the rated torque M_n of 25%

LAGERUNG

- Gebiete im Freien ausschließen, Zonen, die dem Wetter ausgesetzt oder von übermäßiger Feuchtigkeit sind
- Für Lagerungszeiträume über 60 Tage, müssen die Oberflächen die die Kopplungen betreffen und die nicht lackierten Teile in Gusseisen, welche Flansch, Wellen oder Fixierbasis, müssen entsprechend mit Antioxidationsmittel geschützt werden
- Die Dichtringe müssen mit dem Öl befeuchtet werden. Vor der Inbetriebnahme, muss das Öl auf die korrekte vorgesehene Menge aufgefüllt werden
- In Abständen von 4-5 Monaten sollte man mindestens eine Drehung der Welle vornehmen

STORAGE

- Do not store outdoors, in areas exposed to weather or with excessive humidity.
- For storage periods longer than 60 days, all machined and unpainted surfaces such as flanges, bases, and shafts must be protected with a suitable anti-oxidation product
- Oil seals must be touched by the oil. Before putting them into operation restore correct quantity and type of oil.
- At intervals of 4 to 5 months, the output shaft should be rotated

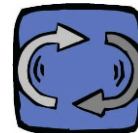

INSTALLATIE

- Sich versichern, dass die Befestigung des Untersetzungsgetriebes stabil ist, um jegliche Vibration zu vermeiden.
- Flüssigkeitskupplungen, Kupplungen, elektronische Drehmomentbegrenzer, Kontrolleinheiten usw. installieren (wenn man Stöße, längere Überlastung oder mögliche Blockierungen vorherieht).
- Für eine gute Leistung unter Einsatzbedingungen auf eine optimale Angleichung des Untersetzungsgetriebes an den Motor und die Maschine, die gesteuert werden muss, achten.
- Jedes Mal, wenn dies möglich ist, empfehlen wir den Gebrauch von elastischen Kupplungen.
- Mit Präzision die Angleichung von eventuellen externen Trägern behandeln, soweit eventuelle Fehler sich in Überlastungen auswirken, mit folgender Zerstörung eines Lagers oder der Welle.
- Vor der Inbetriebnahme der Maschine, sich mittels des Füllstandstopfen versichern, dass die Position des Schmiermittelstandes der Position der Untersetzungsgetriebemontage entspricht.
- Im Falle einer Installation im Freien, angemessenen Schutz und/oder Schutzgehäuse vorhersehen, um eine direkte Einwirkung von Witterungseinflüssen oder Sonneneinstrahlung zu vermeiden.
- Wir empfehlen die Anschlusswellen mit Fett auf Kupferbasis (Beispiel Castrol Optimol Paste HT) zu reinigen und zu schiere, um Korrosion durch Fretting und Festfressen zu vermeiden. Das Kupfer, das ein formare Metall ist, stellt eine Barriere für den direkten Kontakt von ähnlichen Metallen dar, Kontakt, der Ursprung des Festfressens ist. Man kann auch ein Fett auf Ölbasis, das sehr zähflüssig ist, verwenden und das besonders an dem angewendeten Material haften bleibt (Beispiel Mobilgrease XTC).
- In Anwesenheit von externen Lasten, ist es ratsam, Festanschlagstecker zu verwenden.
- Bei den Schrauben und Bindungsebenen ist es unerlässlich selbsthemmende Haftmittel zu verwenden.
- So weit möglich, ist es empfehlenswert, die Montage von Treibrädern zu vermeiden. In jedem Fall den Abstand zwischen Ritzel und Antriebswelle so klein wie möglich zu halten, um die radialen Belastungen zu verringern.
- Die Spannung der Riemen und Ketten minimal halten
- Niemals einen Hammer zur Montage oder Demontage der verkeilten Teile benützen, dagegen die Einschrauböffnungen, die am Kopf an der Welle des Untersetzungsgetriebes vorgesehen sind.
- Für eine korrekte Betriebsweise, ohne Vibrationen und Geräusche, empfiehlt man Motive Maschinen zu verwenden

INSTALLATION

- Make sure that the STON unit is correctly secured to avoid vibrations.
- If shocks or overloads are expected, install hydraulic couplings, clutches, electronic torque limiters, control units, etc.
- For a satisfactory gearbox performance, it is essential to align correctly the motor and the driven machine.
- Whenever possible, we suggest to interpose flexible couplings
- Align with precision the eventual outboard bearing, because any misalignment would cause high overloads, with a subsequent rupture of a bearing or the shaft
- Before starting up the machine, make sure that the oil level is conform to the mounting position specified for the STON unit by checking the level plug
- For outdoors installation provide adequate guards in order to protect the drive from rainfalls as well as direct sun radiation.
- It is recommended to clean and lubricate the connection shafts with grease having a copper base (example Castrol Optimol Paste HT) in order to avoid fretting corrosion and seizure. Copper, in fact, being very malleable, is like a barrier against the direct contact between two similar metals. In alternative, you can use a grease having high viscosity base oil which remains particularly adhesive (example Mobilgrease XTC)
- Whenever there are outer loads, it is recommended to use pins and positive stops
- Self-locking adhesives should be used on the bolts and joining surfaces of the machine frame to prevent gearbox and driven machine to get loose
- It is recommended to avoid to fit cantilever pinions. If this is not possible, minimize the distance between pinion and output shaft to avoid excessive radial loads
- He pre-loading of belts and chains to the minimum
- Never use the hammer for mounting/dismantling of the jeyed parts, but use the tapped holes provided on the head of the shafts
- For a smooth and silent working, it is recommended the use of Motive motors

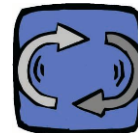

REGELMÄSSIGE KONTROLLEN

Nach 3000 Betriebsstunden, und auf jeden Fall alle 6 Monate:

Ölkontrolle und Ölstandmessung;
Reinigung der Aussenflächen und der Luftwege der Belüftung;
Reinigung des Luftdurchlasses und der Entlüftungskappe;
Sichtprüfung auf Dichtheit der Dichtungen;
Wenn Rückausleger vorhanden Kunststoffbuchse überprüfen und wenn notwendig austauschen;

Nach 20.000 Betriebsstunden, und auf jeden Fall alle 5 Jahre:

Wenn ATEX Version, Wechsel des Synthetischen Oels (wenn Mineralöl, immer den std Anweisungen folgen);
Fett der offenen Lager (z.Bsp.: Nilos Kegelrollager) austauschen, die vom Öl nicht berührt werden;

ROUTINE CHECKS

Every 3.000 working hours, and at least every 6 months:

check oil level;
clean external surfaces and the ventilation air passages;
clean the breather plug air passage;
check visually the absence of leakage from seals visually;
for gear units with a torque arm, check the rubber buffer and change it, if necessary.

Every 20.000 working hours, and at least every 5 years:

if ATEX version, change synthetic oil with with mineral oil, always follow standard instructions);
replace anti-friction bearing grease of open bearings not touched by oil (for instance, taper roller bearings with nilos).

GEBRUIKS TEMPERATUUR

Die Betriebstemperatur hängt von vielen Faktoren ab, welche der zur Übersetzung eingesetzte Getriebetyp, die Menge des Schmiermittels, die angewandte Geschwindigkeit und Leistung, die Umgebung, in der das Untersetzungsgetriebe in Betrieb ist.

Für ein spiralförmiges Getriebe ist die maximale innere akzeptierbare Temperatur 80°C.

Im Falle der Kontrolle, ist es wichtig zu prüfen, dass die Betriebstemperatur, auf die sich das Untersetzungsgetriebe in der Regel einstellt, beständig ist: Zeichen dafür, dass das Getriebe ohne auftretende negative Erscheinungen

- Wenn man einen 2-poligen Motor mit einer Eingangsgeschwindigkeit von ungefähr 2800 Drehungen/Min verwendet, erheben sich einige Probleme, wie die Temperatur, die im Inneren des Getriebes unter Betriebsbedingungen erreicht wird und die Neigung zur Auslösung von Vibrationen oder Geräuschhaftigkeit. Grundsätzlich empfehlen wir den Gebrauch eines Schneckengetriebes mit 2-poligem Motor nur für Anwendungen mit relativ niedrigem Service-Faktor (max. 1,25)
- während der ersten 4 Betriebsstunden, könnte man eine Verringerung der internen Temperatur beobachten, aufgrund der Regelung der verschiedenen Teile in Bewegung.

OPERATING TEMPERATURE

The operating temperature depends on a number of factors such as the type of power transmission, the quantity of lubricant, the speed and power applied and the environment in which the gearbox is operating.

With a standard helical gearbox, the maximum allowable inside temperature is 80°C.

In case of control, it is important to check that the operating temperature when the gearbox runs at normal speed is constant; this indicates that the gearbox is running in a trouble-free manner

- If we use a 2 poles motor (n1 about 2800RPM), a few potential problems, like the temperature inside the gearbox, vibrations or noise, can grow. As a general rule, we recommend the use of wormgearboxes with 2 poles motors only in applications having a relatively low service factor (1.25 max.) and a very low degree of intermittency.

- during the first 4 hours, you may assist to a gradual decrease of the inner temperature due to the gearbox components settling.

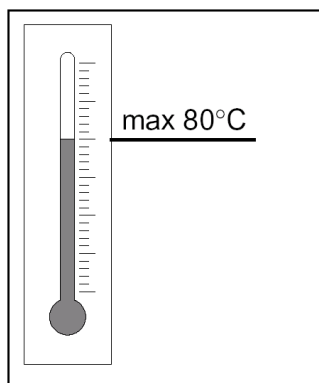

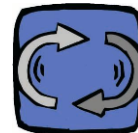

WARTUNG

Die Wartung beschränkt sich im Wesentlichen auf das was im Kapitel "Schmierung" erfordert wird und auf eine sorgfältige äußere Reinigung mit milden Lösungsmitteln, die den Lack nicht ruinieren.

Wenn die Vereinbarkeit zwischen Schmiermitteln entweder nicht besteht oder zweifelhaft ist, und ein neues Auffüllen notwendig ist, empfiehlt man eine komplette Entleerung des Untersetzungsgetriebes vorzunehmen und, bevor man neues Öl eingibt, eine Reinigung zur Entfernung eventueller Rückstände.

MAINTENANCE

Maintenance is essentially limited to the requests reported in the charter "lubrication" and to an accurate external cleaning, usually carried out with bland solvents in order to not to damage the paint

When it is necessary to fill the oil but there is no compatibility of the new oil with the one inside the gearbox, we suggest to empty the gearbox from its oil and wash it before putting the new oil

SCHMIERUNG – LUBRICATION



STON	Ölmenge – Oil quantity (lt)						ISO	Temp.	Ölsorte – Oil type	
	B3	B6	B7	B8	V5	V6				
STON 3	1,05	1,10	1,10	0,95	1,25	1,50	VG 220	-25 +80°C	Fuchs Renolin PG	Shell Omala S4 WE
STON 4	1,90	1,75	1,75	1,65	2,20	2,55				
STON 5	2,20	2,10	2,10	2,00	3,00	3,50				
STON 7	4,80	4,40	4,60	4,30	8,00	7,70				
STON 8	9,30	8,30	8,60	7,80	14,90	13,80				
STON 9	20,60	17,00	16,40	13,60	27,10	26,70				

Jeder STON wird bereits mit dauerhaftem, synthetischem Öl geliefert, mit der Position B3 entsprechender Menge, und erfordert keine Wartung.

Nach vorheriger Zugabe von Öl, kann jeder STON in jeglicher Position montiert werden, und gibt deshalb grosse Vorteile in der Verwaltung des Lagers und den Lieferzeiten.

Unless otherwise specified, each STON is supplied long-life synthetic oil (quantity as per position B3).

After an eventual oil addition, each STON can be mounted in any mounting position, thus giving big advantages in the stock management and lead time

Alle Aggregate werden serienweise mit Füllkappen, Abfluss und Pegelkontrolle geliefert. Außerdem wird ein Entlüftungstopfen gegen Eindringen beigegeben. Vor der Inbetriebnahme ist es angebracht, den Blindstopfen auf der oberen Seite des Untersetzungsgetriebes zu entfernen und ihn mit einem Entlüftungstopfen zu ersetzen.

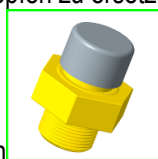

Druckentlastungstopfen



Die Füllstandstopfen, korrekt nach der folgenden Tabelle positioniert, sind ein nützlicher Anhaltspunkt, um die korrekte Ölmenge.

All units are supplied with plugs for loading, discharging and checking the level of the oil. Furthermore, they are accompanied by a breather plug. Before start-up, we suggest to re-place the filler plug in the upper side of the unit with the

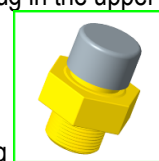

pressure breather plug



Level plugs, correctly positioned as per following tablechart, are a useful reference for the verification of the correct oil quantity.

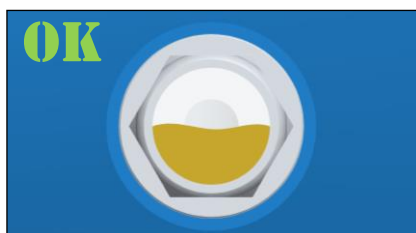

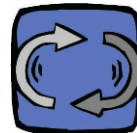

MONTAGEPOSITIONEN – MOUNTING POSITIONS

B3

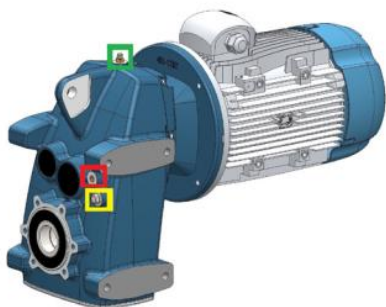

B8

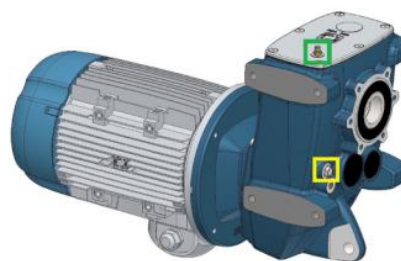

B6

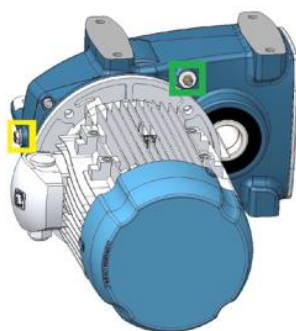

B7

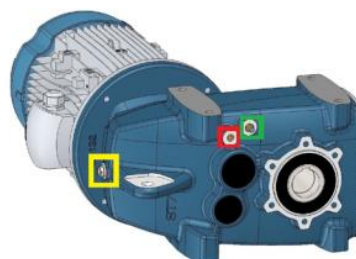

V5



V6



Druckentlastungsstopfen
Pressure breather plug

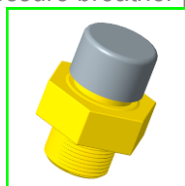

standverschluss
level plug



einfüllverschluss
filler plug



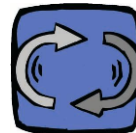

ERSETZEN DES ÖLDICHTRINGES

Wenn eine Dichtung ihre Funktion nicht mehr ausübt, ist es notwendig, sehr schnell für ihre Ersetzung zu sorgen, um zu vermeiden, dass sich der Ölverlust weiter ausbreitet und der Schaden sich auf andere Bestandteile ausdehnt.

Bei der Montage des neuen Öldichtringes ist nötig:

- seine Unversehrtheit prüfen, besonders wenn lange Lagerzeiten seine Alterung, besonders in Anwesenheit von übermäßiger Feuchtigkeit, verursacht haben können
- kontrollieren, dass der Standort des Öldichtringes keine oberflächlichen Fehler besitzt: Wenn eine Beeinträchtigung der Kontaktzone des Öldichtringes auftritt, mit einer höheren Tiefe als 0,2-0,3mm, nicht einen neuen Öldichtring montieren
- beachten, dass die Lippe des neuen Öldichtringes genau auf derselben Spur arbeitet wie der vorgehende
- den Öldichtring senkrecht zur Achse und mit der Lippe absolut frei und nicht umgedreht oder eingeklemmt montieren
- den Öldichtring so orientieren, dass die Dichtungslippe in Richtung Flüssigkeit, die einbehalten werden muss, angebracht ist
- bei den Ringen ohne Staubschutzlippe, das Fett an die äußere Zone der Lippe anbringen
- den Zwischenraum zwischen der Dichtungslippe und der Staubschutzlippe des Öldichtringes mit Fett füllen
- den Standort des Öldichtringes auf der Welle fetten
- keine Dichtungsmasse verwenden, weil sich die Dichtungslippe und die Oberfläche der Welle verschmutzen und schnell beeinträchtigt werden
- die Hammerkraft so nahe wie möglich dem äußeren Durchmesser ausüben
- den Öldichtring nicht axial blockieren und nicht stark beladen
- angemessene Werkzeuge benutzen, um mögliche Schäden an der Dichtungslippe durch die Anwesenheit von Gewinden, Abflüssen, scharfen Kanten und Nuten zu vermeiden
- die Dichtungslippe und ihren Standort auf der Welle schützen, falls man das Untersetzungsgetriebe lackiert

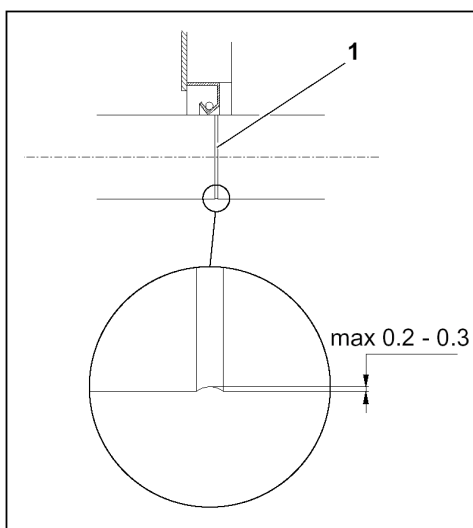

When a shaft seal doesn't work properly, it must be replaced rapidly, in order to avoid that the oil leakage goes further on, and that the damage extends to some other components.

When fitting a new seal, the following precautions are required:

- take particular care in handling, and make sure that the seal is in good conditions, particularly if long times of stocking could have caused a premature wear, especially in presence of excessive humidity
- always check that the shaft seal seat is in good conditions, free of surface defects. If the area where the ring seal comes into contact with the shaft has worn down by more than 0,2-0,3mm, do not install a new seal
- care to prevent the new seal lip from working exactly on the same trace left by the previous one
- fit the shaft seal perpendicularly to the axis, with the lips wholly free, not curled under or pinched
- install the ring seal so that the lip faces the oil that must be kept in or the side from where the pressure is exerted
- for ring seals without a dust-tight lip, coat the outside of the lip with grease
- for ring seals provided with a dust-tight lip, fill the gap between the seal lip and dust-tight lip with grease
- lubricate the seal seat on the shaft
- do not use sealants because if they get on the seal lip or shaft surface, they can cause rapid wear
- when installing the seal, press down as near as possible the outside edge
- do not block the ring seal axially or apply too much load
- always use suitable tools to avoid damaging the seal lip with threads, grooves, sharp edges or keyways
- always cover the seal lip and the seat on the shaft when repainting the gearbox
- use oil seals of the type indicated in table 1

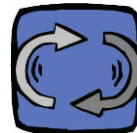

“MF KIT”

Das KIT MF ist aus den notwendigen Teilen zusammengestellt, um selbst einen normalen Flanschen- STON in einen STON+MF umzuwandeln.

Um einen KIT MF zu montieren, erfragen Sie die entsprechenden Anleitungen bei Motive an.

Zu diesen Handlungen, und zur folgenden Abnahmeprüfung, sind nur die Montagezentren und die von Motive zugelassenen Vertriebsstellen berechtigt.

“MF KIT”

“MF KIT” is composed by all the needed parts to transform a standard flange motor-mounting BOX into a BOX+MF.

In order to mount a KIT MF, you must request the specific instructions to Motive.

Only Motive authorized assembly centers and distributors are allowed to make these operations and the consequent final test.

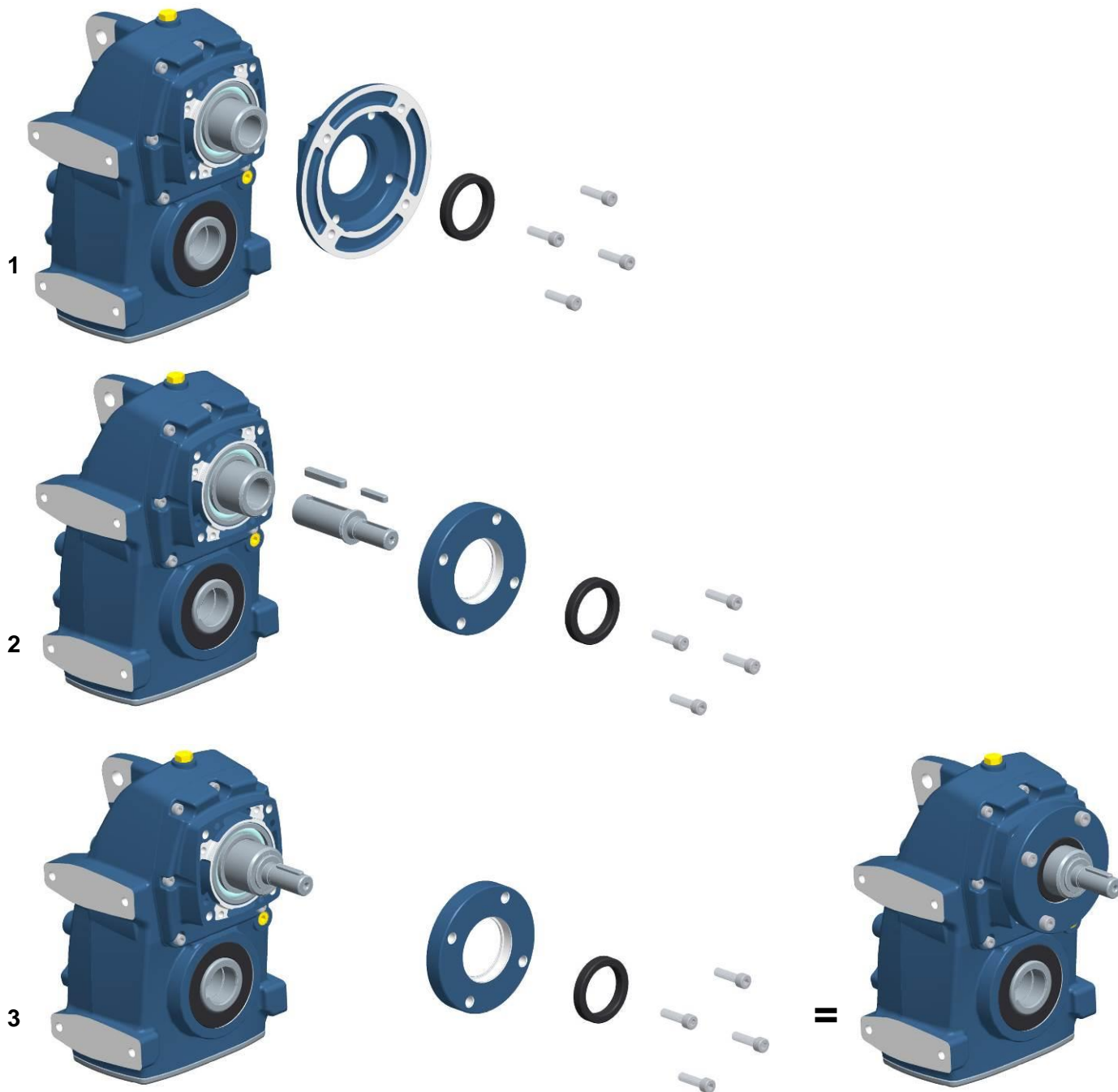

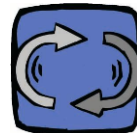

RÜCKAUSLEGER

Maße sind im Katalog in mm angegeben.

Der Hebel ist im Kit nicht beinhaltet, da in der Länge variabel.

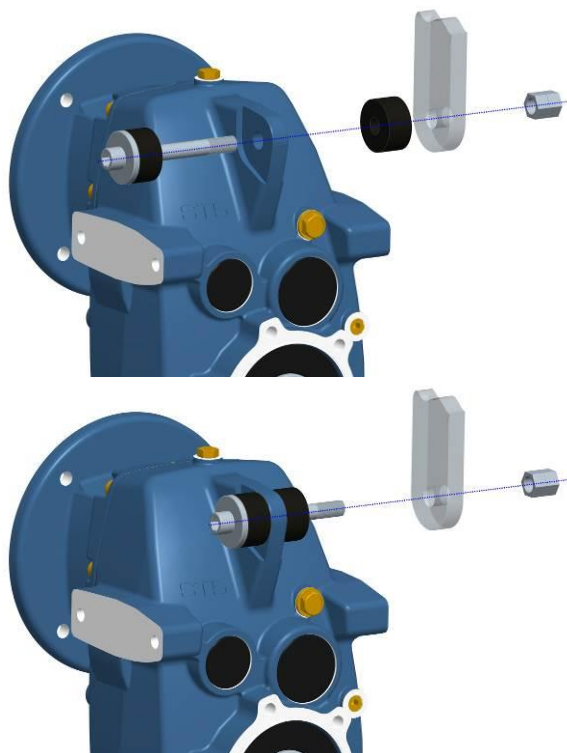

TORQUE ARM

The dimensions in mm are written in the catalogue.

The lever is not supplied in the kit, due to its variable length

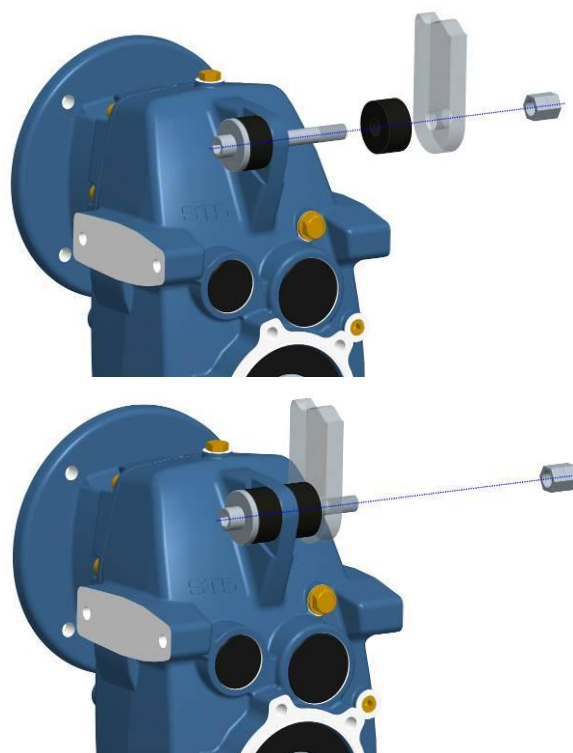

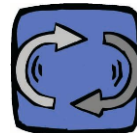

“SOS” ALBERO D’USCITA SINGOLO

Progettato per evitare il suo movimento assiale

“SOS” SINGLE OUTPUT SHAFT

Designed to avoid its axial movement

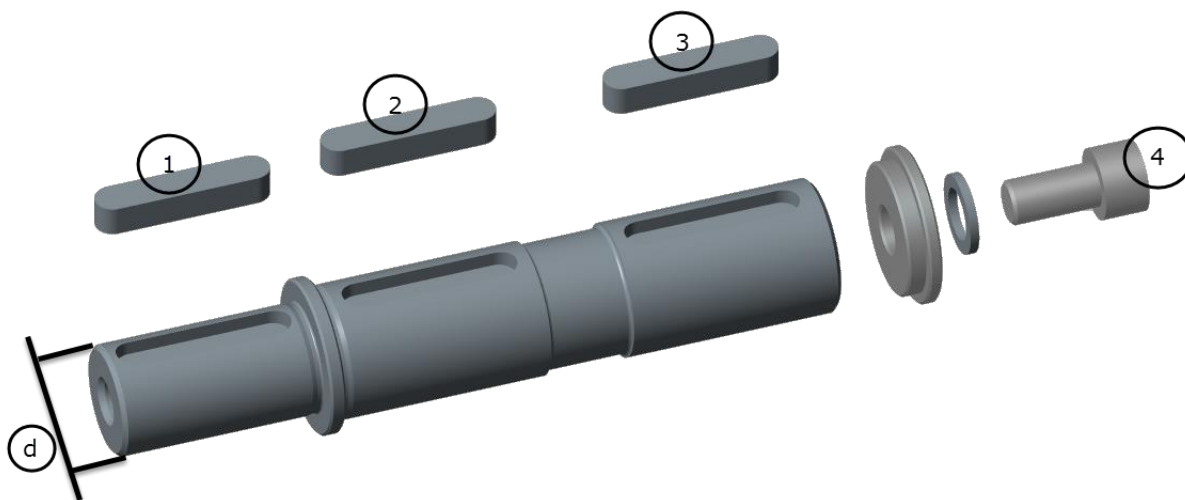

	d	①	②	③	④
STON3	25	8X7X40	8X7X40	8X7X40	M10X20
STON3	30	8X7X50	8X7X40	8X7X40	M10X20
STON4	30	8X7X50	10X8X50	10X8X50	M10X20
STON4	35	10X8X60	10X8X50	10X8X50	M10X20
STON5	35	10X8X56	12X8X56	12X8X56	M10X20
STON5	40	12X8X70	12X8X56	12X8X56	M10X20
STON7	50	14X9X80	14X9X65	14X9X65	M10X25
STON8	60	18X11X110	18X11X80	18X11X80	M12X50
STON9	70	20X12X100	20X12X125	20X12X125	M16X50

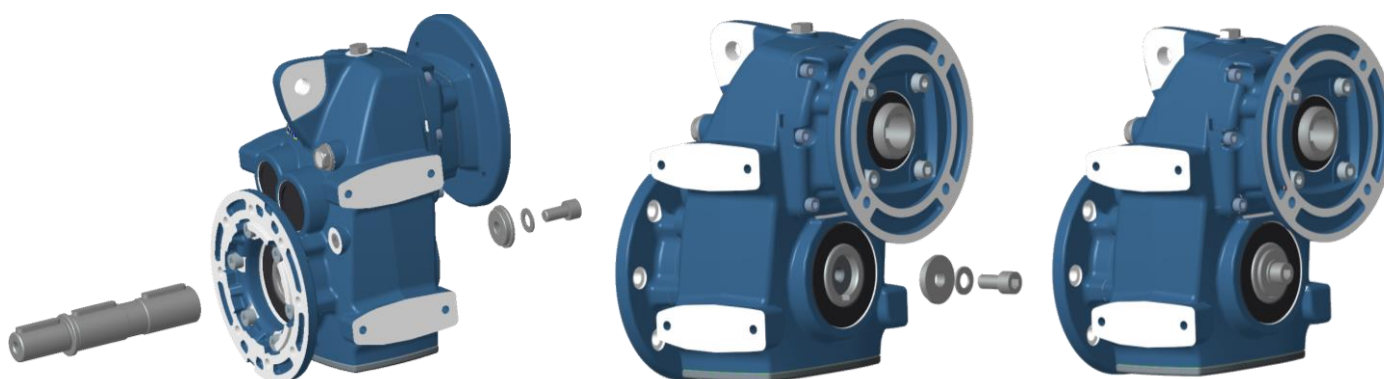

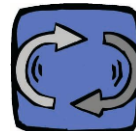

LIMITATORI DI COPPIA

TORQUE LIMITERS

Limitatori di coppia serie standard con regolazione della coppia di intervento SAFEGUARD-SYNCHRON-SAFELIFTING-ROTA FREE

Durante il servizio normale il giunto di sicurezza trasmette la coppia dalla parte mobile (2) alla flangia (3) attraverso una corona di sfere (4° - SAFEGUARD) o di rulli (4b - SYNCHRON, SAFE LIFTING, ROTA FREE, SAFEGUARD-R), costretti dalla pressione delle molle a tazza (6) dentro sedi ricavate sulle due metà (2) e (3) del giunto. Quando la coppia richiesta supera il valore pretarato dalla coppia di intervento, le sfere o i rulli sono spinti fuori dalle loro sedi. Le due metà (2) e (3) si sganciano per sovraccarico, trasmettendo una coppia residua molto bassa, e la parte mobile (2) spinge contro la forza delle molle a tazza (6), ad azionare l'interruttore (9) di comando dell'arresto di emergenza del motore. Il reinserimento è automatico al valore di coppia pretarato quando il sovraccarico cessa.

Nella versione SYNCHRON il reinserimento (a velocità ridotta) avviene dopo 360° dal distacco, così da rispettare il sincronismo fra le due metà (2) e (3) del giunto. Nella versione SAFE LIFTING (impiegata per lo più per sollevamenti), i rulli (4b) non possono uscire completamente dalle sedi, la parte mobile (2) aziona l'interruttore, ma la trasmissione di coppia fra le due metà (2) e (3) del giunto non viene interrotta. Nella versione ROTA FREE adatta per alte velocità, in caso di sovraccarico le due parti (2) e (3) si sganciano completamente e la parte mobile (2) rallenta, folle, fino a fermarsi. Il reinserimento è manuale, martellando leggermente la parte (2) con un martello di gomma.

Torque limiters standard series with torque adjustment SAFEGUARD-SYNCHRON-SAFELIFTING-ROTA FREE

During normal operations the torque limiter transmits the torque from the moving part (2) to the flange (3) through balls (4a - SAFEGUARD) or rollers (4b - SYNCHRON, SAFE LIFTING, ROTA FREE, SAFEGUARD-R) pressed by the disc springs (6) into the indentations on both halves (2) and (3).

In case of overload, when the torque demand exceeds the preset value, both halves (2) and (3) are disengaged and they transmit only a small residual torque. The balls or rollers are pressed out of the indentations, thus pushing the moving part (2) axially against the force of the disc springs (6), and activating a switch (9) to begin the emergency stop of the motor. The re-engagement is automatic at the pre-set torque when the torque demand drops. The SYNCHRON type re-engages (at slow speed) once per revolutions at a reference point and keep the two halves (2) and (3) of the torque limiter synchronised. In the SAFE LIFTING type the rollers (4b) are not allowed to go out completely from the indentations, so that the moving part (2) can activate the switch, but the torque transmission within the two halves (2) and (3) is not interrupted.

In a high speed application, at the moment of overload, the ROTA FREE type will disconnect driven from driver shaft by the complete disengagement of part (2) from part (3), while ring (2) will slow down, idle, up to a stop. Re-engagement must be done manually, lightly taping the part (2) with a soft mallet.

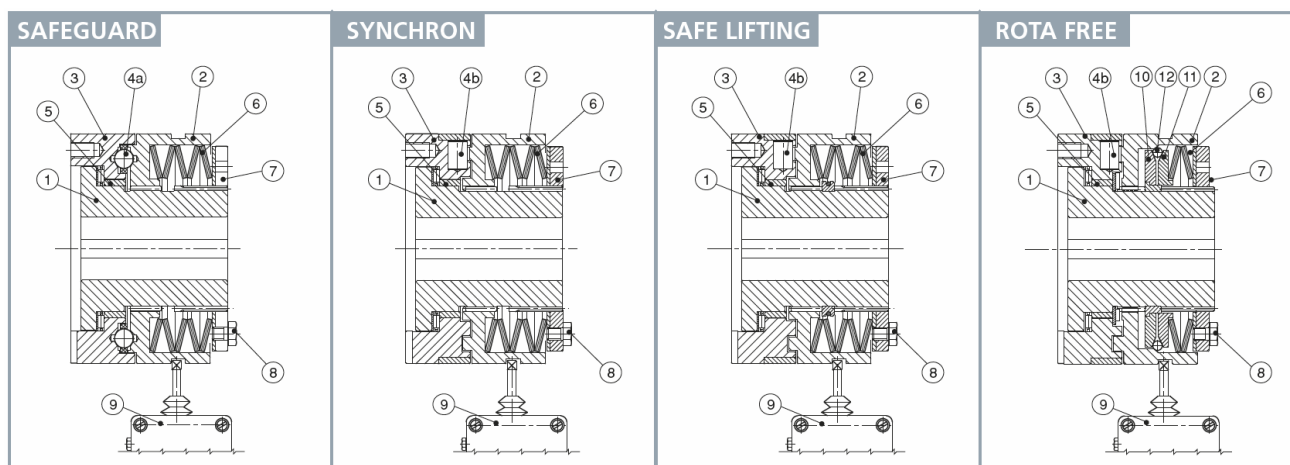

Coppie trasmissibili	min.	2,5 Nm	Diametri fori disponibili	min.	7 mm
Transmissible torque	max.	8200 Nm	Hole diameters available	max.	100 mm



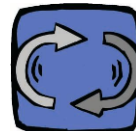

ZBC-NBC Limitatori di coppia a gioco zero

Durante il servizio normale il limitatore di coppia ZBC - NBC (fig.2) trasmette la coppia dal mozzo (1) alla flangia (3) attraverso la corona di sfere (4) costrette dalla pressione delle molle a tazza (6) sulla flangia mobile (2) dentro sedi ricavate sulle parti (1) e (3). In caso di sovraccarico, quando la coppia richiesta supera il valore pretarato, le sfere sono spinte fuori dalle sedi della flangia (3): le due parti (1) e (3) si sganciano trasmettendo una coppia residua molto bassa, e la parte mobile (2) vincendo la spinta delle molle a tazza (6), aziona l'interruttore (9) che comanda l'arresto di emergenza del motore. Il reinserimento è automatico al valore di coppia pretarato quando il sovraccarico cessa.

Nella versione SYNCHRON il reinserimento avviene da fermo o a velocità basse dopo 360° dal distacco, così da rispettare il sincronismo tra la flangia (3) e il mozzo (1). Le molle a tazza lavorano nel solo campo negativo della curva (fig.1) e quindi la ghiera di regolazione (7), ruotata in senso antiorario fornisce un carico crescente alle molle a tazza (6) e quindi una coppia di intervento maggiore. La ghiera (7) è mantenuta in posizione dal bloccaggio della vite di fermo (8). ZBC porta 8 fori filettati di fissaggio e un cuscinetto per servizio pesante, NBC 6 fori filettati di fissaggio e un cuscinetto per servizio leggero.

ZBC-NBC Zero backlash torque limiters

the torque from the hub (1) to the flange (3) through a ball crown (4) forced by the pressure of the disc springs (6) on the moving flange (2) into the seats on the two parts (1) and (3). In case of overload, when the torque demand exceeds the pre-set value, both the parts (1) and (3) are disengaged and they transmit only a small residual torque: the balls are pressed out of the indentations of the flange (3), thus pushing the moving part (2) axially against the force of the disc springs (6), and activating the emergency stop switch of the motor (9). The re-engagement is automatic at the pre-set torque when the torque demand drops. The SYNCHRON type re-engages during stoppage or at low speed once per revolution at a reference point and keep the hub (1) and the flange (3) of the torque limiter synchronised. The disc springs are working only in the negative area of their characteristics (fig.1), so the adjustment nut (7), when tightened anticlockwise, provides an increasing axial load to the disc springs (6) and a higher disengaging torque: when the pre-set torque level is reached the nut (7) is locked in position by means of the locking screw (8). ZBC holds 8 fixing threaded holes and a heavy duty bearing, NBC 6 fixing threaded holes and a light duty bearing.

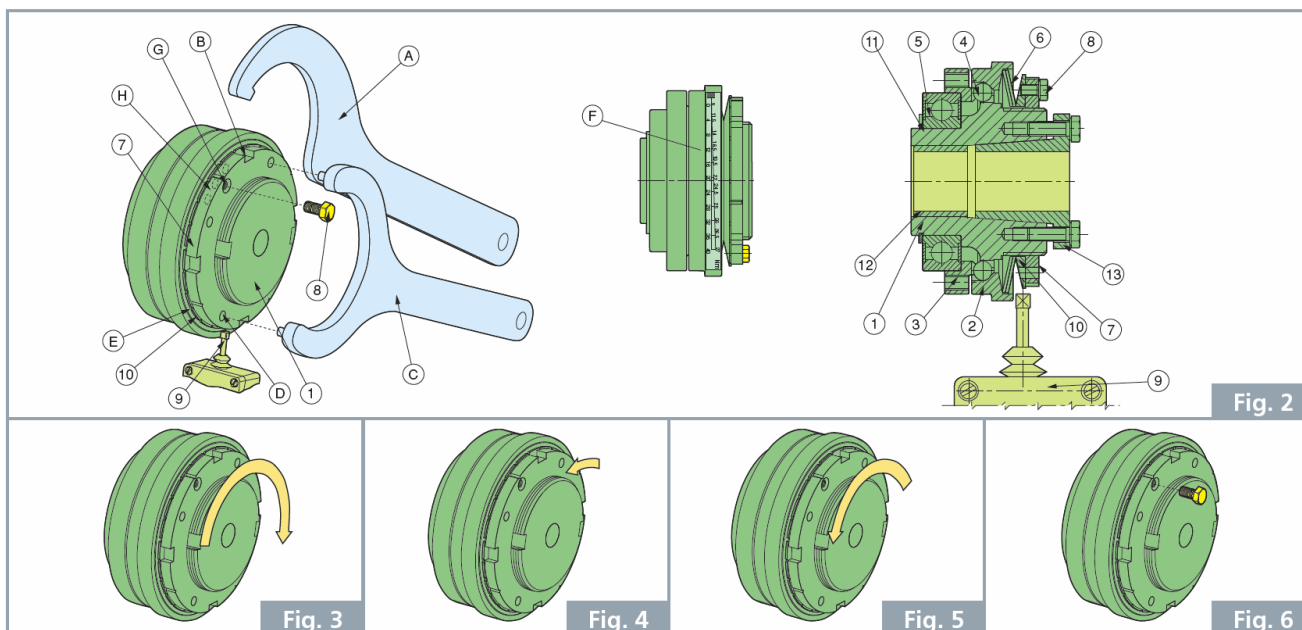

Coppie trasmissibili	min.	0,65 Nm	Diametri fori disponibili	min.	6 mm
Transmissible torque	max.	3100 Nm	Hole diameters available	max.	80 mm



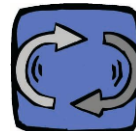

SECUREX Limitatori di coppia a strisciamento con regolazione della coppia di intervento

Il limitatore di coppia Securex agisce come una protezione dai sovraccarichi in azionamenti che impiegano ingranaggi o pulegge.

Si tratta di un dispositivo di impiego molto semplice ed efficace, che offre una completa affidabilità operativa ed è adatto ad applicazioni che comportano sovraccarichi occasionali a basse velocità. Il limitatore di coppia protegge parti meccaniche o macchine che possono essere soggette a sovraccarichi, slittando quando la coppia richiesta oltrepassa un valore pretarato. Mantiene inoltre il reinserimento automatico al

valore di coppia pre-tarato quando il sovraccarico cessa. La coppia di slittamento è tarata al valore richiesto tramite la regolazione del carico delle molle a tazza sulle guarnizioni di attrito.

SECUREX Friction torque limiters with torque adjustment

The torque limiter Securex acts as an overload protection in machine drives using sprockets or pulleys. These devices are extremely simple to use and offer complete operating security for applications involving occasional overloads at low speed.

The torque limiter protects mechanical parts and machines which may be subjected to overloading of various kinds, by slipping when the torque demand exceeds a preset value. It maintains re-engagement at pre-set torque when the overload torque has passed; no resetting is required. Slip torque is presetted by adjustment of the spring force on the pressure plate and friction surfaces.

Coppie trasmissibili	min.	2 Nm	Diametri fori disponibili	min.	5 mm
Transmissible torque	max.	10000 Nm	Hole diameters available	max.	120 mm



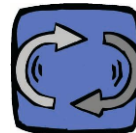

GIUNTI

COUPLINGS

FLEXSTEEL-Giunti lamellari

Flexsteel è un giunto a gioco zero che impiega come elemento di trasmissione un pacco di lamelle in acciaio inossidabile, torsionalmente rigido, ma assialmente e angolarmente flessibile, per compensare disallineamenti fra due alberi; due mozzi metallici sono collegati al pacco lamellare da boccole di precisione e viti ad alta resistenza.

FLEXSTEEL-Lamellar couplings

Flexsteel is a zero backlash coupling which uses a disc pack made of stainless spring steel as a drive element, torsionally stiff, but axially and angularly flexible, to compensate shafts misalignments. Two metal hubs are connected to the discs pack by micrometric precision bushings and highly resistant screws.

Fig. 1A Pacco singolo

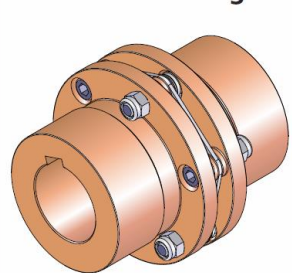

Forma base **A**

Fig. 1B Pacco doppio

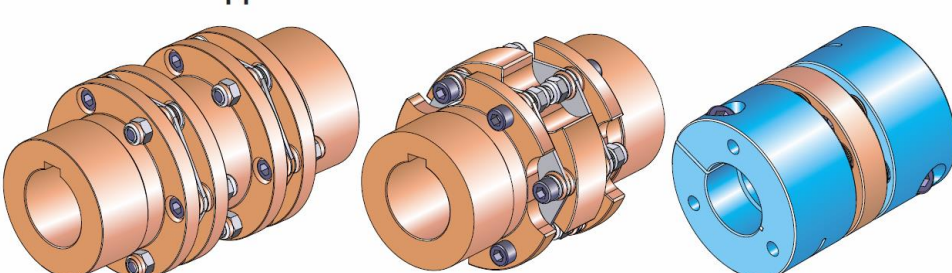

B

B Hmin

S

Coppie trasmissibili Transmissible torque	min.	18 Nm	Diametri fori disponibili Hole diameters available	min.	7 mm
	max.	46000 Nm		max.	180 mm



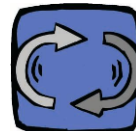

METALFLEX-Giunti a soffietto

METALFLEX è un giunto altamente innovativo, ideale per applicazioni ad alte prestazioni che richiedano ripetibilità, posizionamenti precisi, controllo dei movimenti e dei sincronismi, alte velocità. METALFLEX è composto da due mozzi di alluminio con bloccaggio a morsetto, collegati da una speciale molla in acciaio inossidabile a parete sottile, che rimane rigida sotto carico torsionale, ma è flessibile assialmente, radialmente, angolarmente, per compensare disallineamenti fra gli alberi da collegare: ne risulta un giunto senza gioco, con bassi momenti di inerzia, ad alta rigidità torsionale. Il vantaggio di METALFLEX in confronto ad altri giunti a gioco zero disponibili sul mercato, quali giunti elicoidali o giunti con corona elastica precompressa, consiste nella più alta rigidità torsionale, fattore determinante per la precisione dei posizionamenti: più il giunto è torsionalmente rigido, più precisa è la trasmissione del moto dal motore al componente condotto.

METALFLEX-Bellow couplings

MeTalflex is an innovative coupling for high performance applications requiring repeatability, accuracy in positioning, motion and synchronization control at high speed. MeTalflex is an assembly of two aluminium clamping hubs and a thin walled stainless steel bellow, which remains rigid under torsional load, but it is axially, radially and angularly flexible in order to compensate misalignments within the connecting shafts: the result is a zero backlash high torsional stiffness low inertia coupling. The advantage of MeTalflex against other zero backlash couplings on the market, as beam or curved jaw couplings, is a higher torsional stiffness, key factor for the precision in positioning: a higher torsional stiffness means more accuracy in the motion transmission from the motor to the driven component.

Tipo/Type A **Mozzi a morsetto**
Clamping hubs

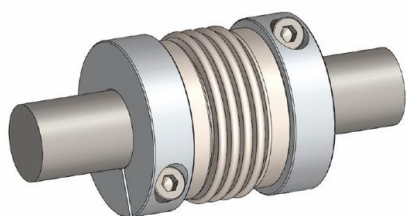

Tipo/Type B **Mozzi scomponibili**
Split hubs

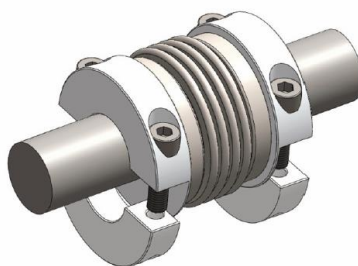

Prima del montaggio
Before mounting

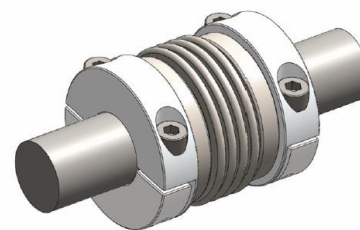

Dopo il montaggio
After mounting

Coppie trasmissibili	min.	1,1 Nm	Diametri fori disponibili	min.	3 mm
Transmissible torque	max.	500 Nm	Hole diameters available	max.	70 mm



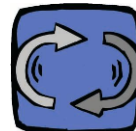

COMPOLASTIC-Giunti elastici

COMPOLASTIC è una serie di giunti composti da due corone dentate in ghisa G25 accuratamente lavorate all'utensile i cui denti lavorano unicamente a compressione su un elemento elastico .

Il particolare e nuovo disegno dell'elemento elastico garantisce una trasmissione del moto con caratteristiche di silenziosità e di durata di vita che sono ai vertici della categoria ed ineguagliabili da ogni altro sistema.

COMPOLASTIC consente inoltre una trasmissione positiva e sicura in ogni circostanza, assorbe le vibrazioni torsionali e compensa importanti disallineamenti assiali, angulari, radiali degli alberi da collegare.

Il materiale dell'elemento elastico centrale consente a COMPOLASTIC di essere impiegato in una gamma di temperature da -30°C a +80°C.

COMPOLASTIC-Elastic couplings

COMPOLASTIC is a series of coupling consisting of two toothed hubs in G25 cast iron, precision machined, whose teeth work only at compression against an elastic element .

The special new design of the elastic element guarantees silent drive transmission and maximum durability for the category that is unequalled by any other system.

COMPOLASTIC ensures a fail safe drive under all conditions, it absorbs torsional vibrations and compensates for important axial, angular and radial misalignments of the shafts to be connected.

COMPOLASTIC can be used at a temperature range of -30°C to +80°C

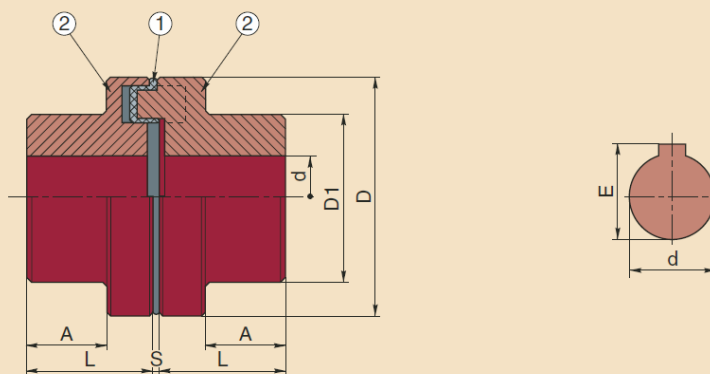

Coppie trasmissibili Transmissible torque	min.	19 Nm	Diametri fori disponibili Hole diameters available	min.	8 mm
	max.	2000 Nm		max.	100 mm



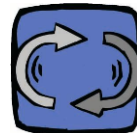

CALETTATORI

SHRINK DISCS

CALETTATORE CONEX SD

Servizio normale

Blocco dall'esterno
Concentricità ottima

CONEX SD-SHRINK DISC

Standard duty

External coupling
Excellent concentricity

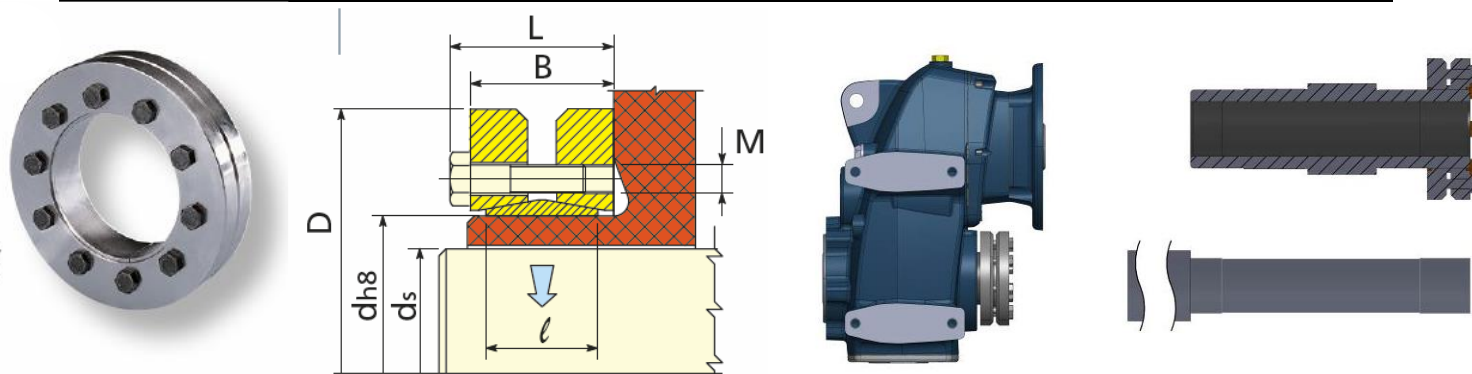

d mm	ds mm	D mm	L mm	B mm	l mm	M	T _s Nm	T Nm	F kN
14	10 - 11 - 12	38	14,5	11	9	M 5	3,5	28 - 38 - 50	5 - 7 - 9
16	12 - 13 - 14	41	18,5	15	11	M 5	4	50 - 70 - 90	9 - 10 - 13
18	14 - 15 - 16	44	18,5	15	12	M 5	4	85 - 100 - 130	16 - 18 - 20
20	15 - 16 - 18	50	22,5	19	14	M 5	4	130 - 150 - 200	20 - 22 - 25
24	19 - 20 - 21	50	22,5	19	14	M 5	5	180 - 210 - 250	26 - 27 - 29
30	24 - 25 - 26	60	24,5	21	16	M 5	6	310 - 340 - 380	26 - 27 - 28
36	28 - 30 - 31	72	27	23	18	M 6	12	460 - 590 - 630	50 - 54 - 58
44	32 - 35 - 36	80	29	25	20	M 6	12	630 - 780 - 860	65 - 74 - 77
50	38 - 40 - 42	90	31	27	22	M 6	12	940 - 1100 - 1300	79 - 85 - 90
55	42 - 45 - 48	100	34	30	23	M 6	12	1200 - 1500 - 1900	80 - 90 - 100
62	48 - 50 - 52	110	34	30	23	M 6	12	1800 - 2200 - 2400	100 - 110 - 120
68	50 - 55 - 60	115	34	30	23	M 6	12	2000 - 2500 - 3100	100 - 110 - 120
75	55 - 60 - 65	138	37,5	32	25	M 8	30	2500 - 3200 - 3900	120 - 140 - 150
80	60 - 65 - 70	145	37,5	32	25	M 8	30	3200 - 3900 - 4600	120 - 140 - 160
90	65 - 70 - 75	155	44,5	39	30	M 8	30	4700 - 6000 - 7200	170 - 190 - 210
100	70 - 75 - 80	170	49,5	44	34	M 8	30	6900 - 7500 - 9000	180 - 220 - 240
110	75 - 80 - 85	185	56,5	50	39	M 10	59	7200 - 9000 - 11000	230 - 250 - 260
115	80 - 85 - 90	188	56,5	50	39	M 10	59	8500 - 10000 - 12000	210 - 240 - 270
120	80 - 85 - 90	215	58,5	52	42	M 10	59	10500 - 13200 - 14400	280 - 300 - 330
125	85 - 90 - 95	215	58,5	52	42	M 10	59	11000 - 13000 - 15000	300 - 320 - 350
130	90 - 95 - 100	215	58,5	52	42	M 10	59	13700 - 15800 - 18200	300 - 330 - 360
140	95 - 100 - 105	230	67,5	60	46	M 12	100	15000 - 17000 - 20000	360 - 400 - 420
155	105 - 110 - 115	265	71,5	64	50	M 12	100	20000 - 23000 - 26000	390 - 420 - 450
160	110 - 115 - 120	265	71,5	64	50	M 12	100	22500 - 25500 - 28600	410 - 440 - 470
165	115 - 120 - 125	290	81	71	56	M 16	250	36000 - 39000 - 44000	630 - 660 - 700
170	120 - 125 - 130	290	81	71	56	M 16	250	31700 - 35800 - 40000	600 - 630 - 660
175	125 - 130 - 135	300	81	71	56	M 16	250	40000 - 44000 - 49000	650 - 680 - 720
180	130 - 135 - 140	300	81	71	56	M 16	250	36800 - 42000 - 46000	560 - 620 - 650
185	135 - 140 - 145	330	96	86	71	M 16	250	55000 - 60000 - 65000	815 - 875 - 896
190	140 - 145 - 150	330	96	86	71	M 16	250	53300 - 58500 - 63500	790 - 830 - 870
195	140 - 150 - 155	350	96	86	71	M 16	250	66000 - 76000 - 82000	950 - 1000 - 1100
200	150 - 155 - 160	350	96	86	71	M 16	250	73700 - 79800 - 85800	980 - 1000 - 1070
220	160 - 165 - 170	370	114	104	88	M 16	250	95000 - 102000 - 110000	1200 - 1300 - 1300
240	170 - 180 - 190	405	121,5	109	92	M 20	490	120000 - 140000 - 160000	1500 - 1600 - 1700
250	180 - 190 - 200	405	120,5	108	92	M 20	490	160000 - 180000 - 200000	1600 - 1700 - 1800
260	190 - 200 - 210	430	132,5	120	103	M 20	490	165000 - 185000 - 204000	1760 - 1878 - 2008
280	210 - 220 - 230	460	146,5	134	114	M 20	490	216000 - 245000 - 270000	2085 - 2220 - 2350
300	230 - 240 - 245	485	154,5	142	122	M 20	490	274000 - 296000 - 316000	2430 - 2560 - 2630
320	240 - 250 - 260	520	154,5	142	122	M 20	490	311000 - 340000 - 375000	2640 - 2780 - 2900
330	250 - 260 - 270	520	154,5	142	122	M 20	490	352000 - 385000 - 420000	2800 - 2900 - 3100
340	250 - 260 - 270	570	168,5	156	134	M 20	490	389000 - 422000 - 459000	3115 - 3245 - 3400
350	270 - 280 - 285	580	174,5	162	140	M 20	490	443000 - 480000 - 500000	3275 - 3430 - 3500
360	280 - 290 - 300	590	174,5	162	140	M 20	490	462000 - 500000 - 530000	3300 - 3460 - 3600
380	290 - 300 - 310	645	183	168	144	M 24	840	570000 - 610000 - 660000	3900 - 4070 - 4260
390	300 - 310 - 320	660	183	168	144	M 24	840	625000 - 670000 - 720000	4170 - 4325 - 4500
400	315 - 320 - 330	680	183	168	144	M 24	840	671000 - 695000 - 745000	4270 - 4340 - 4500
420	330 - 340 - 350	690	203	188	164	M 24	840	782000 - 841000 - 902000	4460 - 5000 - 5200
440	340 - 350 - 360	750	217	202	177	M 24	840	805000 - 861000 - 920000	4760 - 4930 - 5120
460	360 - 370 - 380	770	217	202	177	M 24	840	1000000 - 1073000 - 1141000	5560 - 5820 - 6020
480	380 - 390 - 400	800	228	213	188	M 24	840	1175000 - 1250000 - 1312000	6200 - 6450 - 6580
500	400 - 410 - 420	850	230	213	188	M 27	1250	1314000 - 1382000 - 1460000	6570 - 6740 - 7000

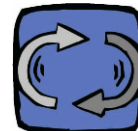

PROBLEME, URSACHEN, ABHILFEN

PROBLEME	URSACHEN	ABHILFE (1)	ABHILFE (2)
Der Motor startet nicht	a) Probleme mit der Versorgung. b) Defekter Motor. c) Falsche Bemessung des Motors	Prüfung der Versorgung	Ersatz des elektrischen Motors
Die Aufnahme des elektrischen Motors erweist sich als höher bezüglich des Sollwertes	Falsche Bemessung des Motors	Prüfung der Anwendung	Ersetzen des elektrischen Motors und eventuell auch des Getriebes
Die auf dem Motorgehäuse gemessene Temperatur ist sehr hoch	a) Defekter Motor b) Fehlerhafte Bemessung des Motors c) Fehlerhafte Bewertung der Motortemperatur	b- Prüfung der Anwendung c- Interne ΔT der Motorwicklung durch Widerstandsänderung	Ersetzen des elektrischen Motors und eventuell auch des Getriebes
Die auf dem Getriebsgehäuse gemessene Temperatur ist sehr hoch	a) Fehlerhafte Bemessung des Untersetzungsgetriebes b) Einbaulage nicht nach Regel c) Ungenügende Menge des Schmiermittels	Prüfung der Anwendung	Wiederherstellung der korrekten Arbeitsbedingungen: Einbaulage und/oder Schmiermittelstand
Die Drehungen der Abtriebswelle des Getriebes sind verschieden von den vorhergesehenen	a) Reduktionsverhältnis verschieden von dem vorhergesehenen b) Motor mit einer verschiedenen Geschwindigkeit als der vorgesehenen	a) Prüfung des Reduktionsverhältnisses b) Prüfung der Motorgeschwindigkeit	Ersetzen des Getriebes und/oder der elektrischen Motors
Ölverlust von den Wellen	a) Beschädigter Öldichtungsring b) Abgenützte Dichtungsstandorte auf der Welle	a) Öldichtungsring ersetzen b) Öldichtungsring ersetzen und ihn in leicht verschobener Position montieren oder die Wellen ersetzen	Weiterleitung des Aggregats an Motive
Ölverlust von den Dichtungen	a) Ungenügende Befestigungen b) Defekte oder beschädigte Dichtungen	a) Die Flanschen verschließen b) Die Dichtungen ersetzen und prüfen, dass die Dichtungsebenen perfekt gearbeitet sind	Weiterleitung des Aggregats an Motive
Die Abtriebswelle dreht entgegengesetzt	Fehlerhafte Verbindung des elektrischen Motors	Zwei Phasen der Versorgung des Motors umkehren	
Zyklisches Rauschen des Getriebes	Dellen an den Zahnrädern	Kein praktisches Problem wenn das Geräusch bei spezifischer Anwendung nicht bedeutend ist	Weiterleitung des Aggregats an Motive, wenn das Geräusch bei spezifischer Anwendung bedeutend ist
Nicht-zyklisches Rauschen des Getriebes	Verschmutzung im Inneren des Untersetzungsgetriebes	Kein praktisches Problem wenn das Geräusch bei spezifischer Anwendung nicht bedeutend ist oder wenn es nach 3 Betriebsstunden verschwindet	Weiterleitung des Aggregats an Motive, wenn das Geräusch bei spezifischer Anwendung bedeutend ist
Geräusch (Pfeifen) vom Getriebe	a) Defekte oder falsch gelegene Lager b) Zahnräder mit Fehler in der Verzahnung c) Spärliche Menge von Schmiermittel	a) Neue Positionierung oder Ersetzen der Lager b) Ersetzen der Zahnräder c) Kontrolle der korrekten Schmiermittelmenge	Weiterleitung des Aggregats an Motive
Vibration auf dem elektrischen Motor	Geometrische Fehler bei der Verkupplung	a) Kontrolle der geometrischen Abweichung der Elektromotorflansche b) Kontrolle der Abweichungen und Geometrien der Taste auf der Motorwelle und sie eventuell mit einer angemessenen ersetzen c) Kontrolle der Vibration des Motors	Ersetzen des elektrischen Motors

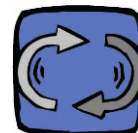

TROUBLE SHOOTING

PROBLEM	POSSIBLE CAUSES	REMEDY (1)	REMEDY (2)
the motor doesn't start	a) problems in the power supply. b) faulty electrical wiring. c) faulty motor. d) wrong size of the motor	check the connections and the power supply	replace the motor.
the current absorption of the electric motor is too high	a) wrong motor size. b) motor faulty.	check the installation/application	replace the motor and eventually also the gearbox
the temperature of the motor frame is too high	a) wrong motor size. b) motor faulty. c) Wrong evaluation of the surface temperature	check the installation/application	replace the motor and eventually also the gearbox
the temperature of the gearbox housing is too high	a) Wrong gearbox size. b) Wrong mounting position. c) Not enough lubricant d) Defective bearing	check the installation/application	correct the mounting position or the lubricant level replace the bearing
output speed is different from expected	a) wrong reduction ratio. b) wrong motor polarity.	a) verify the reduction ratio. b) verify the motor polarity	replace the gearbox and/or the electric motor
oil leaks from the shafts	a) defective seals. b) seal seats on the shafts	a) replace the seals. b) replace the seals and install them in a very slightly different position or replace the shafts.	send the unit to Motive
oil leaks from the seals	a) flanges are not tightened properly. b) defective seals or damaged during the transport	a) tighten the flanges. b) replace the seals, verifying that the seals seats are perfectly worked.	send the unit to Motive
the output shaft turns in the wrong sense	wrong electric motor wiring	invert the position of the 2 phases of the electrical motor power supply	
cyclical noise in the gearbox	damaged gears	no practical problem if the noise is not important in the specific application.	send the unit to Motive if the noise is important in the specific application
not cyclical noise inside the gearbox	dirty inside the gearbox	no practical problem if the noise is not important in the specific application, or if it disappears after 3 working hours	send the unit to Motive if the noise is important in the specific application
a whistling noise is coming from the gearbox	a) defective bearings or not correctly assembled. b) defective gears. c) not enough lubricant	a) reassemble or replace the bearings b) replace the gears c) put the correct quantity of lubricant	send the unit to Motive
vibrations of the electric motor	coupling geometrical errors	a) check the geometrical tolerances of the electric motor flange. Eventually replace b) check geometry and tolerances of the electric motor shaft key. Eventually replace c) Check the motor vibration	replace the motor with a Motive one.

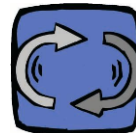

Auf unserer Internet-Seite www.motive.it können Sie den Abschlussbericht der einzelnen Produkte durch eingabe der dazugehörigen Seriennummer downloaden.

On www.motive.it, using the serial number on the nameplate of the gearbox, it is possible to download the Final Test Report of each unit.



Motive wird die Beschwerden des Kunden innerhalb der Grenzen seiner Garantieverpflichtungen (siehe Katalog Motive), in Betracht ziehen, wenn alle Anweisungen bezüglich des Lagerns, der Vorbereitung, der Inbetriebnahme und des Gebrauchs eingehalten werden. Eventuelle Beschwerden müssen zusammen mit der Seriennummer, jedem Detail und Nachweis mitgeteilt werden.

Motive takes into consideration customer's reclamation claims in the frame of the term of guarantee obligations (see Motive catalogue), only if all prescribed conditions for storage, preparation, putting into operation and use are observed. Eventual complaints shall be accompanied by the information of the product serial number and any relevant information and evidence.

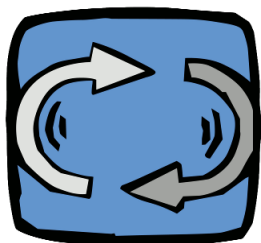

Motive s.r.l.
 motive@motive.it
 www.motive.it
 T +39 030 2677087
 F +39 030 2677125

motive
 power transmission

